

RESCUE® Motors Permanent Split Capacitor Direct Drive Fan & Blower, 5.6" Diameter, Open, Air Over



APPLICATIONS:

Commercial and Residential Air Handlers and Furnaces.
Can replace a range of horsepower applications and a variety of mounting styles.

FEATURES:

- Extended Mounting Studs
- Designed For Use With 370V Capacitors
- Class B Insulation
- 36" Leads
- High Efficiency Design®
- Includes Side Shell Holes For RHEEM® Units
- Continuous Duty, Air Over
- Reversible Rotation
- Automatic Reset Thermal Overload Protector
- 2.5" Dia. Hub Rings Included
- **Discount Symbol: DS-3HAC**

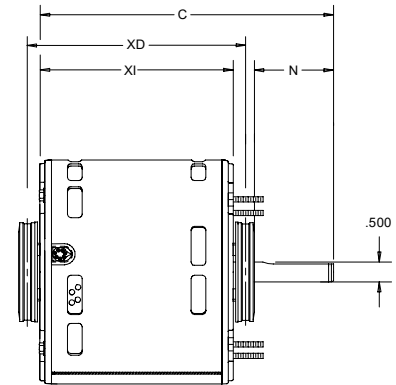

HP	Voltage	Catalog Number	RPM	Cool Speed Tap	Heat Speed Tap	Bearings	Cap. MFD	Amps	Shaft N	Base XD	Shell XI	Total C	Ship Wt.	Notes
1/3	208-230	5469	825	High	Med-Hi	SAB	7.5	2.4	4.5		5.3	9.8	17	H40
1/4				Med-Hi	Med-Lo		7.5	1.7						
1/8				Med-Lo	Low		7.5	0.9						
1/2	115	5460	1075	High	Med-Hi	SAB	10	7.3	5.0	5.8	5.3	10.8	20	H23, H40
1/3				High	Med-Hi		7.5	6.9						
1/4				Med-Hi	Med-Low		7.5	5.5						
1/5				Med-Low	Low		7.5	3.6						
1/6				Low	Low		7.5	2.8						
1/2	208-230	5461	1075	High	Med-Hi	SAB	10	3.6	5.0	5.8	5.3	10.3	15	H23, H40
1/3				High	Med-Hi		5	3.5						
1/4				Med-Hi	Med-Low		5	2.8						
1/5				Med-Low	Low		5	1.9						
1/6				Low	Low		5	1.3						
3/4	115	5470	1075	High	Med-Hi	Ball	20	8.1	5.0	6.6	6.1	11.6	17	H40
1/2				High	Med-Hi		10	6.6						
1/3				Med-Hi	Med-Low		10	4.6						
1/4				Med-Low	Low		10	3.8						
1/5				Med-Low	Low		10	3.1						
3/4	208-230	5471	1075	High	Med-Hi	Ball	20	4.1	5.0	6.6	6.1	11.6	16	H40
1/2				High	Med-Hi		10	3.7						
1/3				Med-Hi	Med-Low		10	2.5						
1/4				Med-Low	Low		10	1.8						
1/5				Med-Low	Low		10	1.7						

Note H23: For 1/3 To 1/6 HP, if more air flow is needed, a 7.5 MFD capacitor may be used

Note H40: Screws For Shell Mounting Included In Carton